



FA416 / FA416D FA416R / FA416DR

Frequency Agile[®] 900MHz
16-Channel / 4-Output Receiver

Installation Instructions

02304D

Document revision history		
Rev. Level	Description	Date
C	Create F:\Eng\parts\02304\02304C.doc from P:\Master.dox\FA_dox\FA416_v3.doc	7/19/01
D	Replace ISO logo	10/08/01

Important Notes

- ▲ This product is designed to be installed and maintained by professional security technicians.
- ▲ Unless specifically noted, Inovonics products are intended for indoor use. This receiver is intended for use with *indoor* security systems. Use in outdoor applications may impair performance.
- ▲ Test system regularly.



Overview:

- The FA416 receiver is a high performance wireless receiver with 4 configurable alarm outputs and 1 global fault output.
- The FA416 has default settings which permit 4 transmitters to be programmed to it. Two of these transmitters may be normally open devices; two may be normally closed devices or have normally closed contacts.
- The FA416R and FA416DR have 5 onboard Form C relays. In all other respects they are identical to the FA416 and FA416D.
- When the FA516 display module is added to the FA416 or FA416R, the assembly is designated the FA416D and the FA464DR, respectively. The FA416D(R) can program and supervise 16 transmitters, with assorted default assignments of external contact types and outputs. The display module indicates point numbers and status of transmitter alarm and faults.
- The FA116 programmer can be used with either the FA416, FA416D, FA416R or FA416DR. The programmer lets the user change all default settings for transmitters and outputs. With the FA116, users can program 16 points into the FA416 without the FA516 display module. The FA116 also has a signal level and signal margin monitoring function, making it very useful for site surveys and troubleshooting.

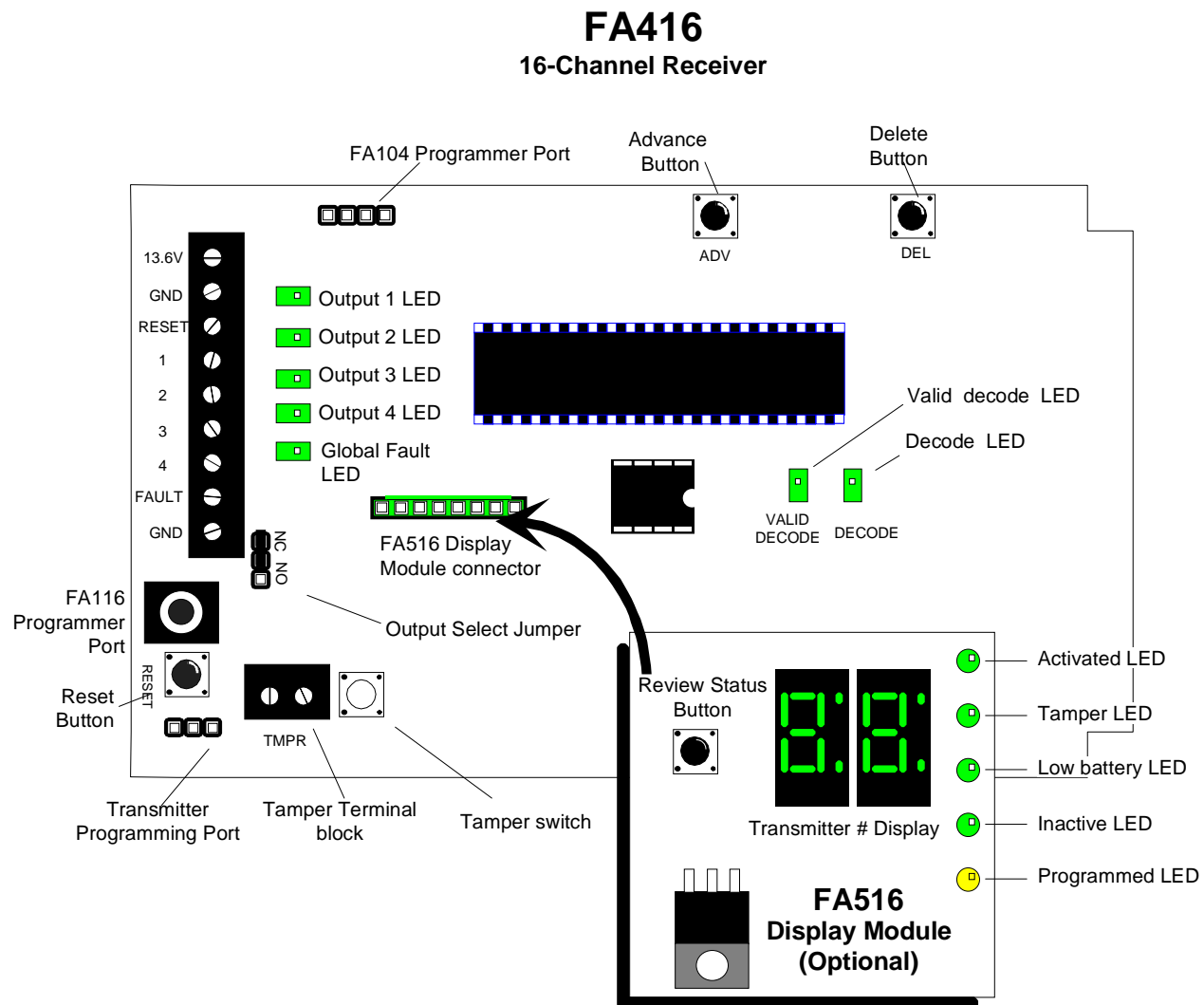
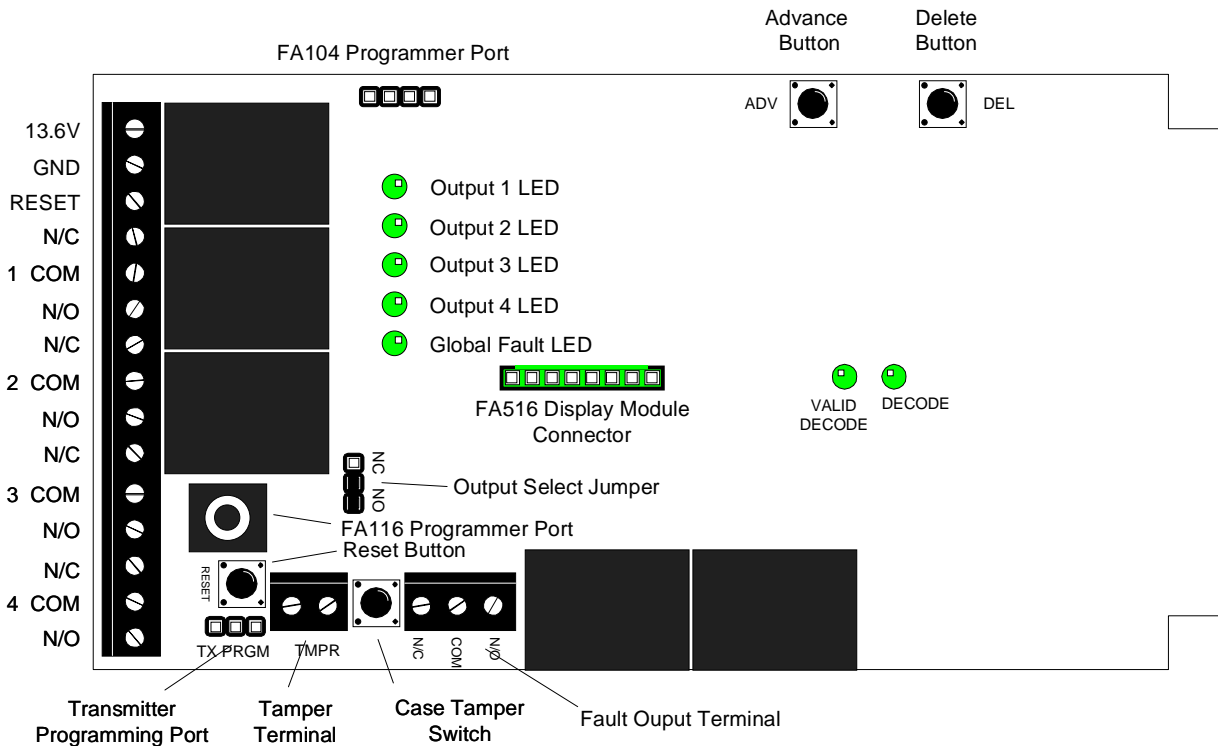

Figure 1: FA416 / FA416D receiver

Note: References in this manual to features shown in Figure 1 will be printed in *italics*.

Figure 2: FA416R / FA416DR receiver



Note: References in this manual to features shown in Figure 2 will be printed in *italics*.

To open housing, insert small flat screwdriver at top or bottom pry point indicator nubs (4 places). **Gently** twist or pry housing cover away from base. Prying at any other location will damage the housing.

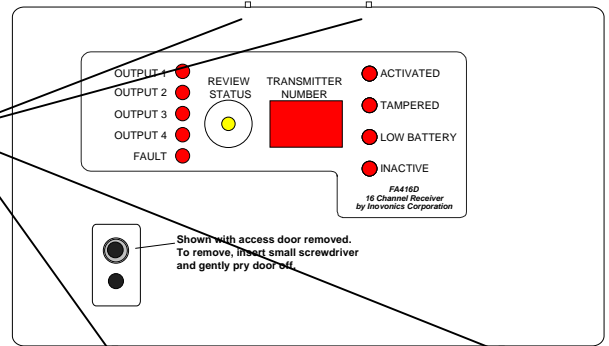

Figure 3: FA416D / FA416DR receiver housing

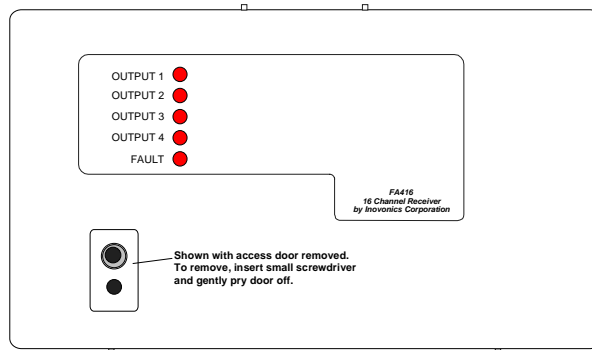

Figure 4: FA416 / FA416R receiver housing

Features of the FA416 include:

- Fully supervises up to 16 FA transmitters.
- Outputs can be configured Normally Open or Normally Closed via **Output select jumper**. (One configuration for all outputs.)
- For N/O configuration, output is open relative to ground. On activation, output pulls to common ground.
- For N/C configuration, output is held at common ground. On activation, output releases to open circuit.
- Technicians can observe output function by monitoring voltages between channel outputs and power on the FA416 or resistance on the FA416R relay outputs.
- Transmitter, receiver and output options are factory assigned. They may be changed with the FA116 Executive Programmer or with the FA104 (upgraded C104) programmer.
- Intelligent global fault output for tamper, low battery and inactive transmitters. For example, if one of the alarm outputs is assigned to monitor low battery faults, the fault output automatically becomes tamper and inactive only.
- Manual and/or electronic reset of the receiver.
- Factory default programming: "Alarm" and "Inactive" outputs are programmed to follow transmitter status; "Tamper" and "Low battery" outputs are latching. Latched outputs require the receiver to be reset.
- Simple restoral to factory defaults.
- Automatic exit from programming after 4 minutes of inactivity.
- Optional FA516 display module available.
- Cabling knockout in housing base.
- Cabling port with separate shutter.
- Case tamper switch and terminal block for connection to panel zone.

Additional features of the FA416D include:

- Status LEDs on the display module show transmitter activation, tamper, low battery and inactive.
- The **Programmed LED** blinks when the point IS NOT programmed, is on steady when the point IS programmed.

Additional features of the FA416R and FA416DR include:

- Form C relays for alarm and fault outputs.

Technical Specifications:

Dimensions (housing):	6.38" x 3.60" x 1.10"
Weight:	6.9 oz. 9 oz FA416R and FA416DR
Environmental:	
Operating temperature:	32°-140°F (0°-60°C)
Relative Humidity:	95% (non-condensing)
Electrical:	
Power Requirement:	11 - 14 VDC, 450 mA
Power Consumption:	60 - 85 mA (without display) 75 - 225 mA (with display) 450 mA (with display and 5 relays active)
Typical:	60 mA (without display) 75 mA (with display) 115 mA (with display and 1 relay active)
Relay specifications:	1A @ 28VDC 0.5A @ 30VAC (resistive load)
Receiver:	
Type:	frequency-hopping spread spectrum
Operating frequency:	902-928 MHz

Installation:

Power: Supply power and ground to terminals marked **13.6V** and **GND** on the terminal block.

Mounting: Use supplied hardware to attach FA416 housing to wall or surface. Where possible, orient the antenna side of the receiver toward the majority of transmitters on the site. This enhances reception.

Opening the housing: Insert a small flat screwdriver behind pry point indicator nubs on top or bottom of the housing cover. Gently twist or pry the housing cover away from the base.

Installing the FA516 display: Always disconnect power from the FA416 receiver before installing or removing the FA516 Display Module. Visually check the mating of pins and header to make sure that all pins are seated in the header.

Note: If the FA516 display is purchased separately from the FA416, it will be packaged with a housing cover and graphic panel to replace the original FA416 cover. (Specify housing type.)

Installing the case tamper: Connect leads from the Case Tamper terminal block to a zone on the hardware panel. The switch is N/C with the cover on.

Attention: The FA540 relay module is not compatible with the new FA416 and FA416D receivers. If relay outputs are required, the receiver unit must be either the FA416R or the FA416DR . The FA541 single-relay module can still be used to provide relay operation off of individual outputs.

Connecting FA416-version receivers to a panel: When the FA416 will be used with a hardwire security panel, the panel will supply 12VDC power and ground to the FA416. Typically, the ground supplied to the receiver is common to the input loops of the hardwire panel. **NOTE: Ground from the panel to the receiver MUST be common on the FA416 and FA416D. Otherwise, the FA416R or FA416DR must be used.** Receiver outputs are connected by one wire each to their respective zone input loops on the panel. With the output jumper in normally open position, outputs may be wired in parallel to a single loop on the panel.

Figure 5: Typical connections between the FA416 and a hardwire panel:

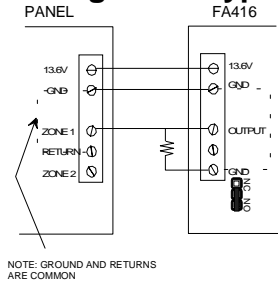

In this diagram, the FA416 output jumper is set to N/O. The panel pull-down resistor is installed in parallel with the output wire for EOL supervision.

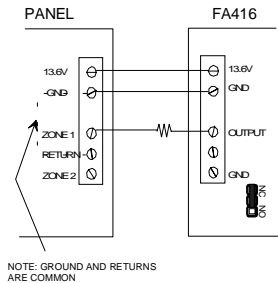

In this diagram, the FA416 output jumper is set to N/C. The panel pull-down resistor is installed in series with the output wire for EOL supervision.

Figure 6: Typical connections between the FA416R and a hardwire panel:

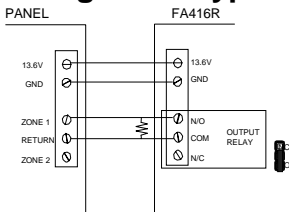

In this diagram, the FA416R output jumper is set to N/O. The panel zone return is NOT common to the receiver ground, so a separate wire is needed from relay common to panel zone return.

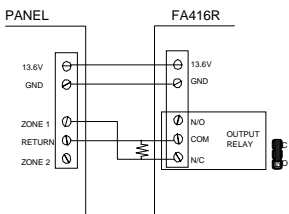

This configuration effectively monitors receiver power, since power failure causes relays to reset, tripping all zones which are wired as shown. The FA416R output jumper is set to N/C, in effect reversing polarity. The panel zone return is NOT common to the receiver, so a separate wire is needed from relay common to panel zone return. Since the loop is effectively N/O as long as the receiver is powered, the panel pull-down resistor is installed in series with the output wire for EOL supervision.

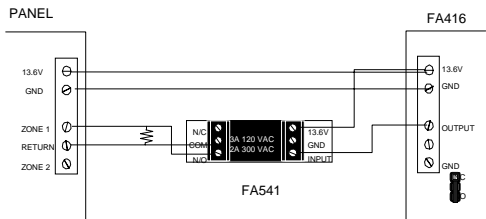

In this diagram, the FA416 output jumper is set to N/O. An FA541 relay module is used to provide dry contact switching to the control panel. Note that the wire from the FA416 output goes to the "Input" terminal of the relay module. **NOTE: setting the output jumper to N/C**

Programming transmitters:

Refer to "Overview", page 2, for a description of programming features. This section describes programming transmitters by directly connecting them to the receiver. Note that the FA116 programmer permits users to change all receiver and transmitter options.

Default programming without the FA516 display module: Transmitters are connected to the FA416 with the programming cable. When the desired Output LED is turned on, the transmitter is programmed by pressing the transmitter reset button.

1. Refer to Appendices A and B to determine available pre-programmed parameters. Default transmitter parameters for the FA416 are: Channels 1 and 2 will program transmitters for Normally Open external switch contacts, Channels 3 and 4 will program transmitters for Normally Closed external switch contacts.
2. Select a point number which matches desired transmitter parameters.
3. Press the **Advance button** on the FA416 as often as needed to turn on the **Output LED** for the desired transmitter channel. (Output LED 1 equals point # 1, etc.) The LED will blink if the point has not been programmed. If a transmitter has already been programmed to that channel, the LED will be on steady.
4. Connect the programming cable to the transmitter and then to the **Transmitter Programming Port** on the FA416.
5. Press the transmitter reset button. (Refer to Appendix C.) When the transmitter is successfully programmed the selected channel LED will briefly go on solid and then will go out. (It may be necessary to press the transmitter reset button more than once, if the receiver is "busy" with signals from other transmitters.)

Default programming with the FA516 display module: Up to 16 transmitters can be selected and programmed. The **Channel Display** indicates the point number, the red LEDs show point status and the green **Programmed LED** indicates if the point is programmed or not. The **Review button** on the FA516 is pressed to indicate current status of transmitters. The **Review button** is also used to exit programming mode.

1. Refer to Appendices A and B to determine available pre-programmed receiver and transmitter parameters.
2. Select a point number which matches desired transmitter parameters.
3. Use the **Advance button** on the FA416 to change the **Channel Display** to the point desired. (Hold the **Advance button** to scroll rapidly through points.) The green **Programmed LED** will indicate unprogrammmed points by flashing, programmed points with constant "on". In addition, the LED for the output **assigned** to the point being programmed will also be "on".
4. Connect the transmitter to the **Transmitter Programming Port** with the programming cable.
5. Press the transmitter reset button. The **Programmed LED** will turn on solid indicating programming is accomplished. (It may be necessary to press the transmitter reset button more than once, if the receiver is "busy" with signals from other transmitters.)
6. To program additional transmitters, repeat Steps 1-5.
7. To exit program mode, press the **Review button** or the **Reset button**.

Receiver Operation:

Output activation: Outputs will open or close upon activation of the point. This function is determined collectively for all outputs by placement of the **Output Select Jumper**. (If the jumper position is changed after transmitters have been programmed, it will be necessary to press the receiver **Reset Button**.) Activation of an output is indicated by the corresponding **Output LED** on the FA416 board. The fifth LED is the **Global Fault LED**.

Fault output operation: By default, the **Global Fault Output** will activate upon recognition of a trouble condition. Tamper and Low Battery signals will cause the **Global Fault Output** to latch. Inactive conditions will follow the current state of the transmitter.

A point is declared inactive as follows: The receiver looks for at least one supervisory transmission (or "check-in") from each supervised transmitter during the period of time programmed as the supervisory window. The first time the receiver gets a supervisory signal from a transmitter within a new window, it considers the transmitter active for the remainder of the window. If it fails to receive a signal in the following supervisory window, it declares the point inactive at the end of the window. The actual time between a transmitter becoming inactive and being reported inactive will range from slightly more than the supervisory window value to slightly less than twice the window period. For example, the default supervisory window is 4 hours. If a transmitter becomes inactive, the inactive fault output will be triggered in 4 to 8 hours.

IMPORTANT NOTE: For most applications, Inovonics recommends a 4-hour supervisory window. In conjunction with a 60-second transmitter check-in interval, this provides highly reliable supervision. If significantly shorter supervisory windows or for significantly longer check-in periods are desired, please consult Inovonics technical service.

Note: If another output is assigned a global fault function, such as global tamper, that function will no longer be reported at the Global Fault output.

Displaying fault and active conditions without the display: Fault conditions will cause the **Global Fault LED** to light. It can be reset via the **Reset input** or the **Reset button**. Without the display or the FA116 programmer, trouble-shooting global faults is primarily a matter of deduction and of systematically checking transmitters for low batteries and tamper conditions. Inactive transmitters which have previously worked well can usually be attributed to low batteries.

Displaying fault and active conditions with the display: Faults can be identified by point and type. Press the **Review button** on the FA516 while observing the status LEDs. Trouble conditions will be indicated by LEDs on the FA516 and the point will be shown on the **Channel Display**. The display will show multiple faults, by stepping through each trouble type in sequence, showing points affected. If a point is activated and/or in trouble the **Output LEDs** will indicate which output is assigned to the activated and/or troubled point.

Resetting outputs: All outputs can be reset either by pressing the **Reset button** or by pulling the **Reset input** terminal to ground. This can be done by installing a switch between the reset input and the ground terminal on the receiver. Remote or automatic resetting can be accomplished by relay control from the hardwire panel. **All** outputs are cleared. If a transmitter remains in alarm or if a fault condition is not corrected, the output will reactivate at the next supervisory signal received from the transmitter.

Figure 6: Typical reset circuit:

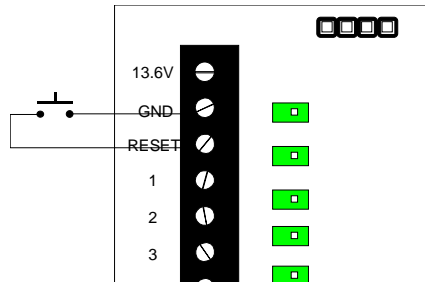

Deleting points without the FA516: Only points 1 through 4 may be deleted.

1. Illuminate the appropriate channel LED with the **Advance button**.
2. Press the **Delete button**. The channel output LED will begin to flash when the point is deleted.

Deleting points with the FA516: Points 1 through 16 may be deleted.

1. Use the **Advance button** to show the desired point on the **Channel Display**.
2. Press the **Delete button** on the FA416 board. The **Programmed LED** will change from steady "on" to flashing.

Restoring factory defaults: This sequence restores default receiver, output and transmitter parameters. It also clears all programmed points. **Note: the receiver access code is reset.** See Appendices A and B.

1. Press and hold the **ADV button**.
2. Press and release the **RESET button**. The **Decode** and **Valid Decode** LEDs will go out.
3. Release the **ADV button**.
4. Press and hold the **DEL button**.
5. Watch the Decode LED. When the LED flashes, release the **Delete button**.

Using the FA116 programmer keypad: Program all 16 points with or without the FA516 display module. Options which may be programmed include end-of-line resistor, internal contact (widegap magnet), changing external switch configuration, check-in time interval and desired output channel. In addition, receiver parameters may be changed, including supervisory window. See Appendix B.

Troubleshooting Guide:

- **The transmitter is programmed, but is not tripping the output.**

Try programming the transmitter again. If you have an FA116 programmer, check the output assignment.

Check the signal level to make sure the device is transmitting. See if the transmitter works nearer to the receiver.

- **An output other than the one indicated in Appendix B is being activated.**

The receiver's output configuration may have been reprogrammed. Use an FA116 to confirm this, and to make changes as needed.

- **The transmitter is tripping the receiver, but the receiver is not tripping the panel (or output device).**

If the transmitter is turning on the correct output LED, but the receiver is not tripping the equipment to which it is attached, check the wiring between receiver and panel. Make sure that panel EOL resistors are properly wired into the zone loop. Try tripping the panel directly. Some panels need dry contact loops, requiring relays between the receiver and the panel. In these cases, either insert the FA541 relay module or replace the receiver with an FA416R or FA416DR model.

- **How do I measure receiver output operation with a volt-ohm meter?**

Measure voltage between the output terminal and the power terminal. For N/C output jumper select setting, voltage will switch from supply voltage to near-zero as the output is tripped. For N/O output jumper select setting, voltage will switch from near-zero to supply voltage. Measuring resistance (continuity) in the ground-to-output circuit is not reliable due to impedance characteristics of the open-collector output circuit.

- **What does resetting the transmitter do?**

Resetting the transmitter recovers the parameters last programmed into the transmitter. It does not erase the programming or cause the transmitter to stop transmitting.

- **What does it mean when all of the LEDs come on at the same time?**

Check wiring connections. Also check placement of the FA516 display module in its socket.

- **Does resetting the receiver to factory defaults clear all programming too?**

Yes, but it does NOT reset access code to "3446"..

- **The fault LED is staying on. What is wrong?**

Press the Review Status button (FA416D and FA416DR) to see the point number and type of fault. Unless changed with an FA116 programmer, Low Battery and Tamper Conditions will latch the fault output until the receiver reset button is pressed. Once the cause of the fault had been determined and corrected, press the receiver reset button.

- **What does the type of transmitter used have to do with the Output Loop selection?**

Absolutely nothing. They are separate options. Transmitters can be programmed as Normally Open or Closed devices, or any combination thereof, and the output loop can be Normally Open or Normally Closed, according to the needs of the system.

Appendix A:

Default Receiver Parameters

<u>Output</u>	<u>Active on Condition</u>	<u>Programmable Options</u>
1	Alarm	Alarm / Alarm+Tamper / Disabled
2	Alarm	Alarm / Alarm+Tamper / Disabled
3	Alarm	Alarm / Alarm+Tamper / Disabled
4	Alarm	Alarm / Alarm+Tamper / Disabled

<u>Transmitter Condition</u>	<u>Default Mode</u>	<u>Programmable Options</u>
Alarm	Follower	Follower / Momentary / Latching
Inactive	Follower	Follower / Momentary / Latching
Tamper	Latching	Follower / Momentary / Latching
Low Batt	Latching	Follower / Momentary / Latching

Default Momentary Output time: 4 seconds

1 - 16 seconds

Default Receiver Parameters:

System ID:	(randomly assigned at factory)	0 - 255
Point supervision:	Yes	Yes / No
Supervision window:	4 hours	1 - 99 minutes, 1 - 99 hours
Access code:	3446	0000 - 9999
Vision Plus compatible:	No	Yes / No (Refer to FA116 user manual)

Programmable Options may be modified only by using the FA116 Executive Programmer.

Appendix B:

Default Transmitter Parameters

<u>Point</u>	<u>Switch Contact</u>	<u>Output Channel</u>	<u>Check-in Seconds</u>
1*	N/O	1	60
2*	N/O	2	60
3*	N/C	3	60
4*	N/C	4	60
5	N/O	1	60
6	N/O	2	60
7	N/O	3	60
8	N/O	4	60
9	N/C	1	60
10	N/C	2	60
11	N/C	3	60
12	N/C	4	60
13	N/C	1	60
14	N/C	2	60
15	N/C	3	60
16	N/C	4	60

*Only points 1 through 4 can be programmed from the FA416 and FA416R. Points 1-16 may be programmed from the FA416D and FA416DR. The FA116 programmer can be used to change any transmitter options on any receiver for all 16 points.

Note: Portable panic transmitters which may be taken off-site or out of range or should nonetheless be programmed to check in. After a transmitter has been programmed, the receiver programming for that point should be changed (with an FA116) so that the transmitter will not be declared inactive.

Appendix C:
FA200
Universal Transmitter

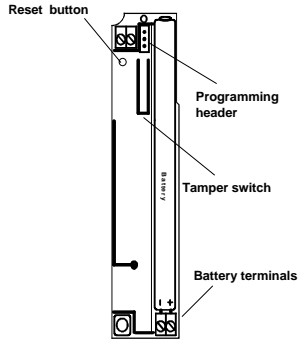

Program contacts: N/O or N/C, as needed
 EOL resistor: as needed
 Typical battery life: 3 years
 Battery type: 4.5V alkaline battery
 Switch trigger: 1.5 seconds, minimum
 Dimensions: 1.25" x 6.00" x 0.750"

Frequency Agile™ Series Transmitters
FA200W
Universal Widegap Transmitter

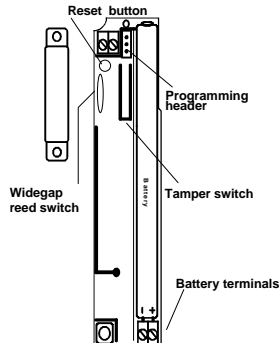

Program contacts: N/O or N/C, as needed
 EOL resistor: as needed
 Internal contact: as needed
 Typical battery life: 3 years
 Battery type: 4.5V alkaline battery
 Switch trigger: 1.5 seconds, minimum
 Dimensions: 1.25" x 6.00" x 0.750"

FA202
Smoke Detector

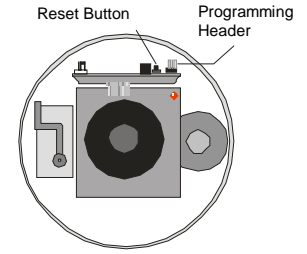

Program contacts: N/C
 Typical battery life: 1 year
 Batteries (2): 3V lithium
 Dimensions: 6.0" Diameter

Note: Remove jumper to program, replace jumper after programming.

FA203
Pendant Transmitter

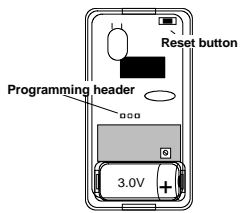

Program contacts: N/O
 Typical battery life: 3-5 years
 Battery (or equivalent): 3.0V lithium Sanyo CR2
 Dimensions: 3.10" x 1.62" x 0.750"

* To extend battery life, actual check-in interval of the FA203 is 2 to 3 times the programmed value.

FA204
Pendant Transmitter

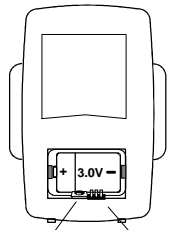

Note: Remove battery cover to access Reset Button and Programming Head

Program contacts: N/O
 Typical battery life: 2 years
 Battery: 3.0V Sanyo LiMn CR14250
 Dimensions: 2.8" x 1.7" x 0.83"

FA205
Beltclip Transmitter

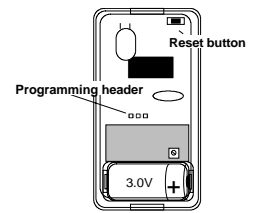

Program contacts: N/O
 Typical battery life: 3-5 years
 Battery (or equivalent): 3.0V lithium Sanyo CR2
 Dimensions: 3.10" x 1.62" x 0.750"

* To extend battery life, actual check-in interval of the FA205 is 2 to 3 times the programmed value.

FA206S
PIR Motion Detector

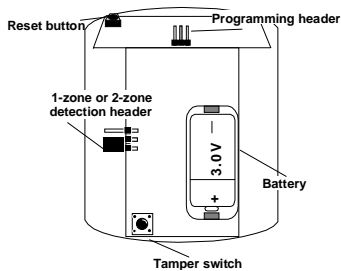

Program contacts: N/C
 Typical battery life: 2 years
 Battery: 3.0V lithium Duracell DL123A
 Sleep after trip: 90-103 seconds
 Dimensions: 3.75" x 2.88" x 2.40"

FA206DS
PIR Motion Detector

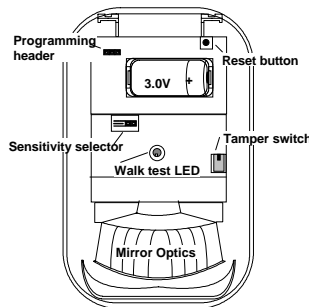

Program contacts: N/C
 Typical battery life: 2 years
 Battery: 3.0V lithium DL123A
 Sleep after trip: 180 seconds
 Dimensions: 3.75" x 5.75" x 2.50"

FA207
Glassbreak Detector

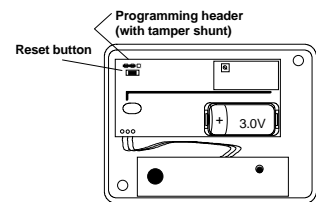

Program contacts: N/O
 Typical battery life: 2 years
 Battery: 3.0V lithium DL123A
 Dimensions: 4.25" x 3.12" x 1.63"

Note: Remove jumper to program, replace jumper after programming.

Note: Batteries are always supervised. Lithium batteries are capacity-tested at 18-hour intervals. Typical battery life is based on 60-second check-in. The transmitter will deactivate 2 weeks after low battery is detected.

Frequency Agile™ Series Transmitters (Continued)

**FA209
Billtrap Transmitter**

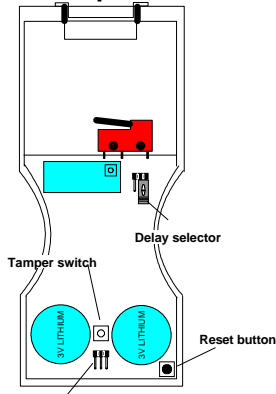

Programming header
 Program contacts: N/O
 EOL, internal contacts: No
 Typical battery life: 1-2 years
 Battery type (Qty. 2): 3.0V lithium CR2450N
 Dimensions: 2.63" x 6.19" x 0.750"

**FA210
Reduced-size
Universal Transmitter**

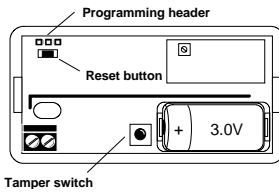

Program contacts: N/O or N/C, as needed
 EOL resistor: as needed
 Typical battery life: 4 years
 Battery type: 3.0V lithium DL123A
 Switch trigger: 1.5 seconds, minimum
 Dimensions: 3.55" x 1.70" x 0.920"

**FA210W
Reduced-size
Universal Widegap Transmitter**

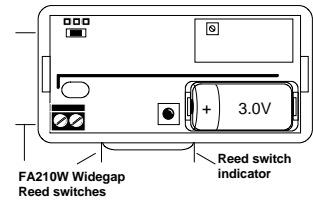

Program contacts: N/O or N/C, as needed
 EOL resistor: as needed
 Internal contact: as needed
 Typical battery life: 4 years
 Battery type: 3.0V lithium DL123A
 Switch trigger: 1.5 seconds, minimum
 Dimensions: 3.55" x 1.70" x 0.920"

**FA250
High Power Transmitter**

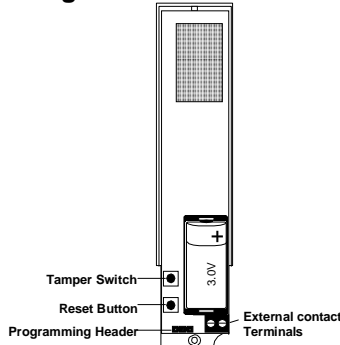

Program contacts: N/O or N/C, as needed
 EOL resistor: as needed
 Typical battery life: 1-2 years
 Battery type: 3.0V lithium DL123A
 Switch trigger: 1.5 seconds, minimum
 Dimensions: 1.25" x 6.00" x 0.750"

Note: Batteries are always supervised. Lithium batteries are capacity-tested at 18-hour intervals.
 Typical battery life is based on 60-second check-in.
 The transmitter will deactivate 2 weeks after low battery is detected.

COMPANY: _____

PROGRAMMED BY: _____

ADDRESS: _____

CITY: _____

PHONE: _____

ATTN: _____

Default Receiver Output Parameters

Output	Default Active on		CHOICES	
1	Alarm	Alarm	Alarm+Tamper	Tamper
2	Alarm	Low Battery	Inactive	Tamper+Low Battery
3	Alarm	Tamper+Inactive	Low Battery+ Inactive	Any Tx fault
4	Alarm	Disabled		

Default Transmitter Output mode

Condition	Default Mode		CHOICES	
Alarm	Follower	Follower	Momentary	Latching
Inactive	Follower	Follower	Momentary	Latching
Tamper	Latching	Follower	Momentary	Latching
Low Batt	Latching	Follower	Momentary	Latching

Default Momentary Output time: 4 seconds
Programmable Output time: 1 - 16 seconds **CHOICE:** _____ seconds

Default Receiver Parameters

Programmable Options

CHOICE

System ID:	(random)	0 - 255	_____
Point supervision:	Yes	Yes / No	_____
Supervision window:	4 hours	1 - 99 minutes, 1 - 99 hours	_____
Access code:	3446	0000 - 9999	_____
Vision Plus compatible:	No	(See FA116 user manual) Yes / No	_____

Default Transmitter Parameters

- External Contacts options: **N/O or N/C**
- 2.2K EOL resistor options: **Yes or No (in external contact loop)**
- Internal Contact options: **Yes or No (FA200W and FA210W widegap only)**
- Output channel options: **1 - 4**
- Check-In interval options: **Unsupervised / 10, 30 or 60 seconds / 5 or 60 minutes / 8 or 18 hours**

Point#	DEFAULT				CHOICE					
	External Contact	EOL	Internal Contact	Output#	Check-in	External Contact	EOL	Internal Contact	Output#	Check-in (HR/SEC)
1	N/O	No	No	1	60 SEC					
2	N/O	No	No	2	60 SEC					
3	N/C	No	No	3	60 SEC					
4	N/C	No	No	4	60 SEC					
5	N/O	No	No	1	60 SEC					
6	N/O	No	No	2	60 SEC					
7	N/O	No	No	3	60 SEC					
8	N/O	No	No	4	60 SEC					
9	N/C	No	No	1	60 SEC					
10	N/C	No	No	2	60 SEC					
11	N/C	No	No	3	60 SEC					
12	N/C	No	No	4	60 SEC					
13	N/C	No	No	1	60 SEC					
14	N/C	No	No	2	60 SEC					
15	N/C	No	No	3	60 SEC					
16	N/C	No	No	4	60 SEC					

Appendix D

Warranty & Disclaimer

Inovonics Wireless Corporation ("Inovonics") warrants its products ("Product" or "Products") to conform to its own specifications and to be free of defects in materials and workmanship under normal use for a period of twenty-four (24) months from the date of manufacture. Within the warranty period Inovonics will repair or replace, at its option, all or any part of the warranted product. Inovonics will not be responsible for dismantling and/or reinstallation charges. To exercise the warranty, the User ("User", "Installer" or "Consumer") must be given a Return Material Authorization ("RMA") Number by Inovonics. Details of shipment will be arranged at that time.

This warranty does not apply in cases of improper installation, misuse, failure to follow installation and operating instructions, alteration, abuse, accident or tampering, and repair by anyone other than Inovonics.

This warranty is exclusive and expressly in lieu of all other warranties, obligations or liabilities, whether written, oral, express, or implied, including any warranty of merchantability or fitness for a particular purpose. Inovonics will not be liable to anyone for any consequential or incidental damages for breach of this warranty or any other warranties.

This warranty will not be modified, varied or extended. Inovonics does not authorize any person to act on its behalf to modify, vary or extend this warranty. This warranty will apply to Inovonics Products only. All other products, accessories or attachments used in conjunction with Inovonics equipment, including batteries, will be covered solely by their own warranty, if any. Inovonics will not be liable for any direct, incidental or consequential damage or loss whatsoever, caused by the malfunction of Product due to products, accessories, or attachments of other manufacturers, including batteries, used in conjunction with Inovonics Products.

This warranty does not warrant the replacement of batteries that are used to power Inovonics Products.

The User recognizes that a properly installed and maintained security system may only reduce the risk of events such as burglary, robbery, personal injury and fire. It does not insure or guarantee that there will be no death, personal damage and/or damage to property as a result. **Inovonics does not claim that the Product may not be compromised and/or circumvented, or that the Product will prevent any death, personal and/or bodily injury and/or damage to property resulting from burglary, robbery, fire or otherwise, or that the Product will in all cases provide adequate warning or protection.**

Inovonics shall have no liability for any death, injury or damage, however incurred, based on a claim that Inovonics Products failed to function. However, if Inovonics is held liable, directly or indirectly, for any loss or damage arising under this limited warranty or otherwise, regardless of cause or origin, Inovonics' maximum liability will not in any case exceed the purchase price of the Product, which will be fixed as liquidated damages and not as a penalty, and will be the complete and exclusive remedy against Inovonics.



Warning: The User should follow all installation, operation and maintenance instructions. The User is strongly advised to conduct Product and systems tests at least once each week. Changes in environmental conditions, electric or electronic disruptions and tampering, may cause the Product to not perform as expected.

Warning: Inovonics warrants its Product to the User. The User is responsible for exercising all due prudence and taking necessary precautions for the safety and protection of lives and property wherever Inovonics Products are installed. Inovonics strongly advises the User to program Products to be supervised whenever used in applications affecting life safety. Users are warned that unsupervised devices are subject to undetected failure due to malfunction, battery failure, tampering, or changes in environment.



**Frequency Agile[®] Receivers
from *Inovonics*:**

FA401	Single Channel / Single Output
FA401R	Single Channel / Single Relay Output
FA404	4-Transmitter / Single Output
FA404R	4-Transmitter / Single Relay Output
FA416	16-channel / 4-output
FA416D	16-channel / 4-output with display
FA416R	16-channel / 4-relay output
FA416DR	16-channel / 4-relay output with display
FA464DR	64-channel / 16-relay output with display

Receiver Accessories:

FA116	Executive Programmer for FA416 / FA464 / C404
FA516	Display module for FA416 and FA416R
FA541	Single-channel form 'C' relay module

**Inovonics Wireless Corporation
315 CTC Blvd
Louisville CO 80027
FAX: (303)939-8977
E-MAIL: support@inovonics.com**

www.inovonics.com

**Sales and Technical Service:
800 782-2709**